

6

5

4

3

2

1

TYPE	OUTPUT		POLE	TIME RATING	VOLTAGE V	Hz	SYN. SPEED R.P.M
	HP.	kW.					
AEEHED	250	186	6	CONT	460	60	1200

TOTALLY ENCLOSED FAN-COOLED VERTICAL SOLID SHAFT TYPE, SQUIRREL CAGE ROTOR

NOTE:

1. DIMENSIONS IN INCH
2. FRAME NO.449VP
3. F CLASS INSULATION, S.F.: 1.15
4. FOR DIRECT COUPLING.
5. BEARING SIZE:  
UPPER BEARING: 7326B (UNINSULATED)  
LOWER BEARING: 6318C3 (UNINSULATED)
6. LUBRICATION:  
UPPER BEARING USE OIL.  
OIL VISCOSITY: ISO VG68 [300SSU AT 100°F]  
OIL QUANTITY: 1.8 GAL.  
LOWER BEARING USE GREASE.(MOBIL POLYREX EM)
7. ROTATION: COUNTER-CLOCKWISE [VIEW FROM TOP].
8. WITH NON-REVERSE RATCHET MECHANISM.
9. APPROXIMATE WEIGHT: 3180
10. REED FREQUENCY: 34 HZ
11. DOWNTHRUST: 10,000 LBS (L10-8800HRS)
12. SPACE HEATER RATED AT 120 VOLT, SINGLE PHASE, 109 WATTS, LEADS TERMINATE IN MAIN LEAD BOX.

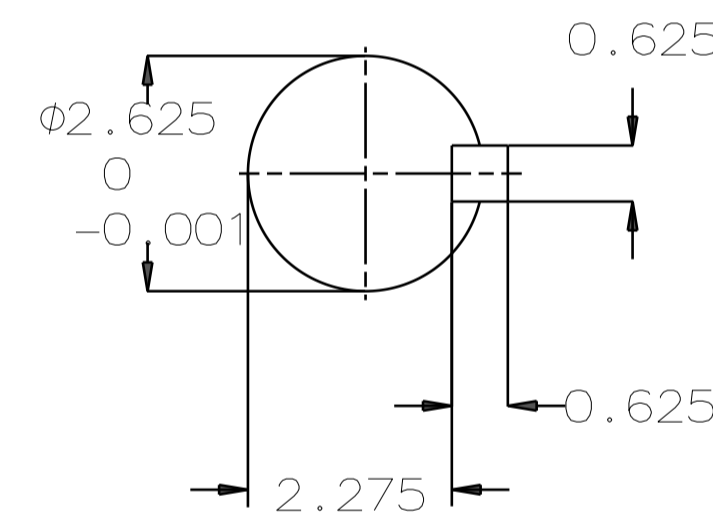
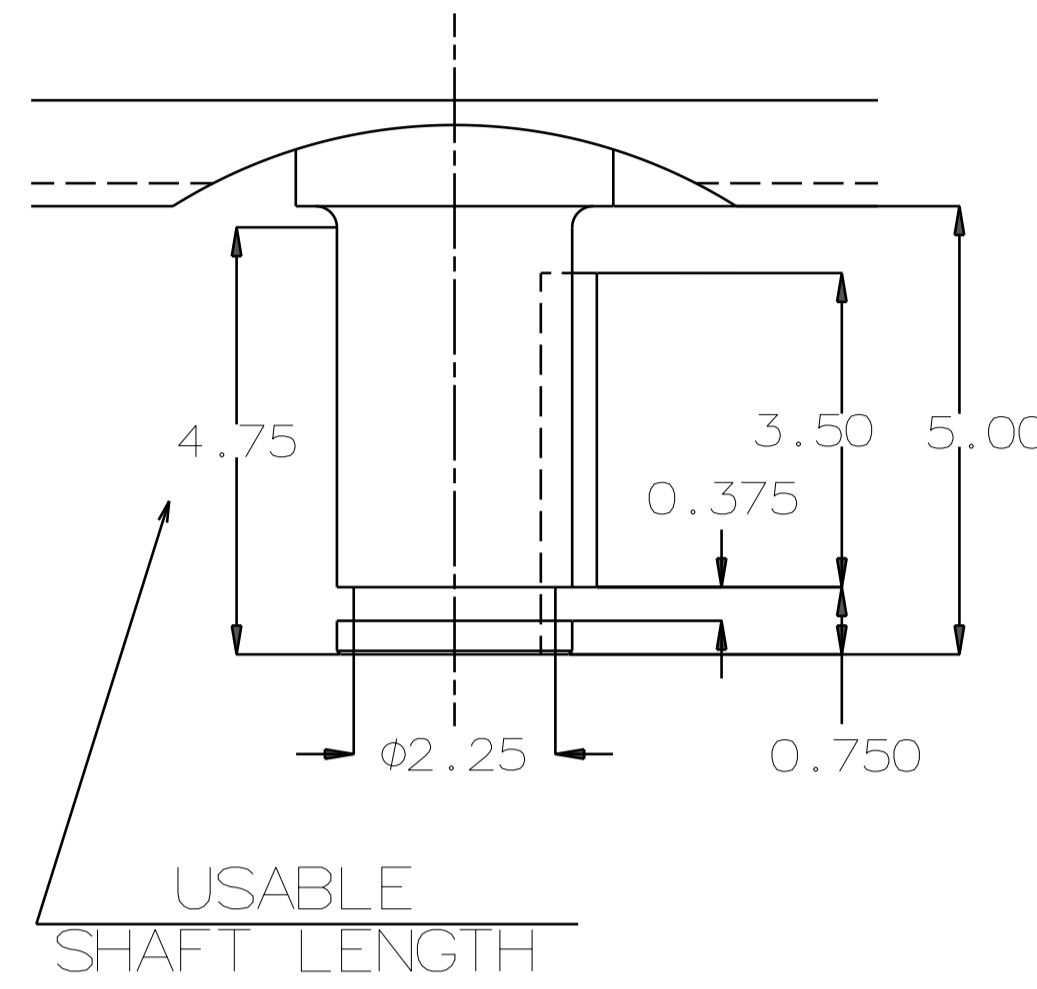
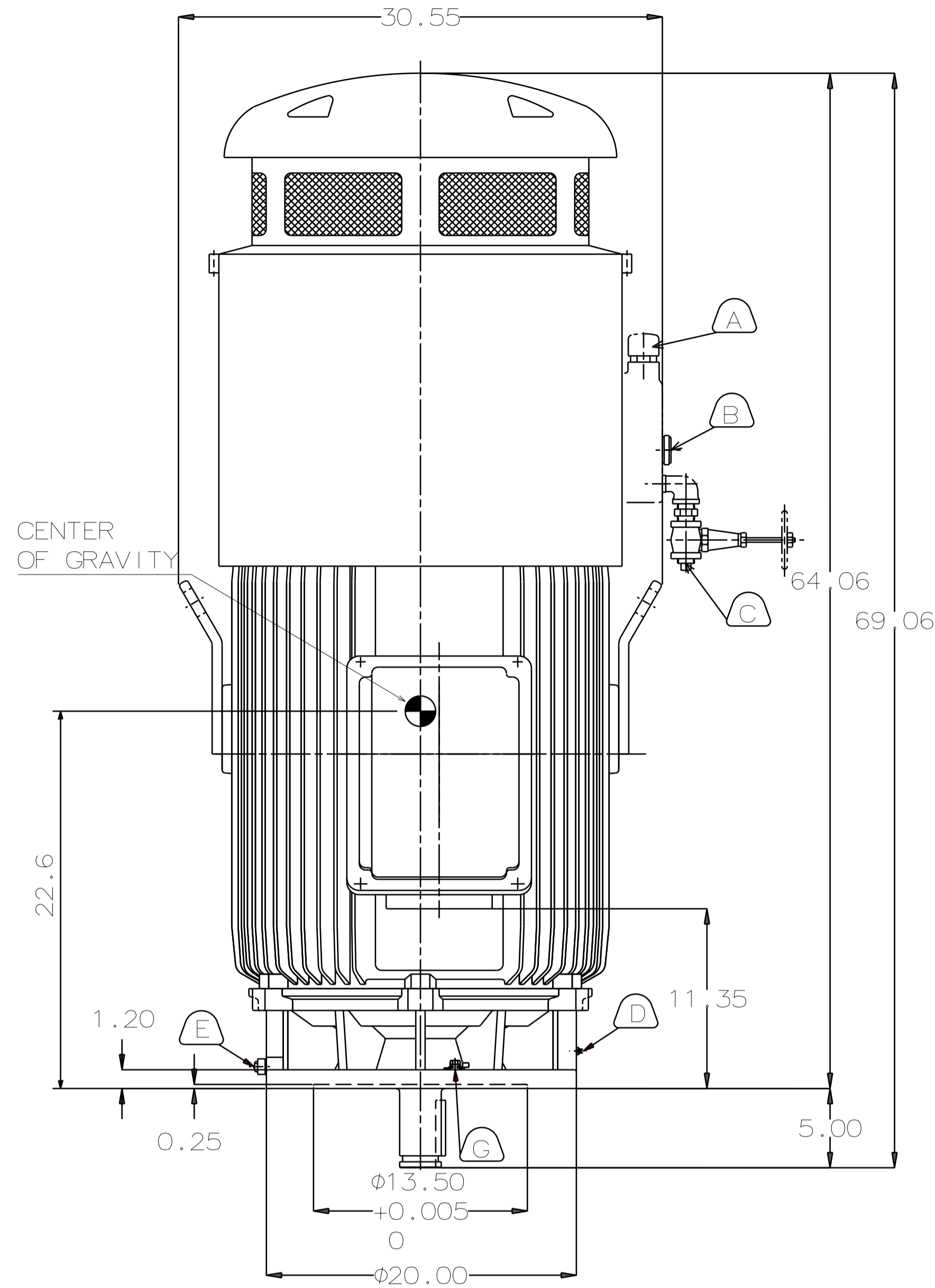

01 SHAFT END [ENLARGED VIEW]

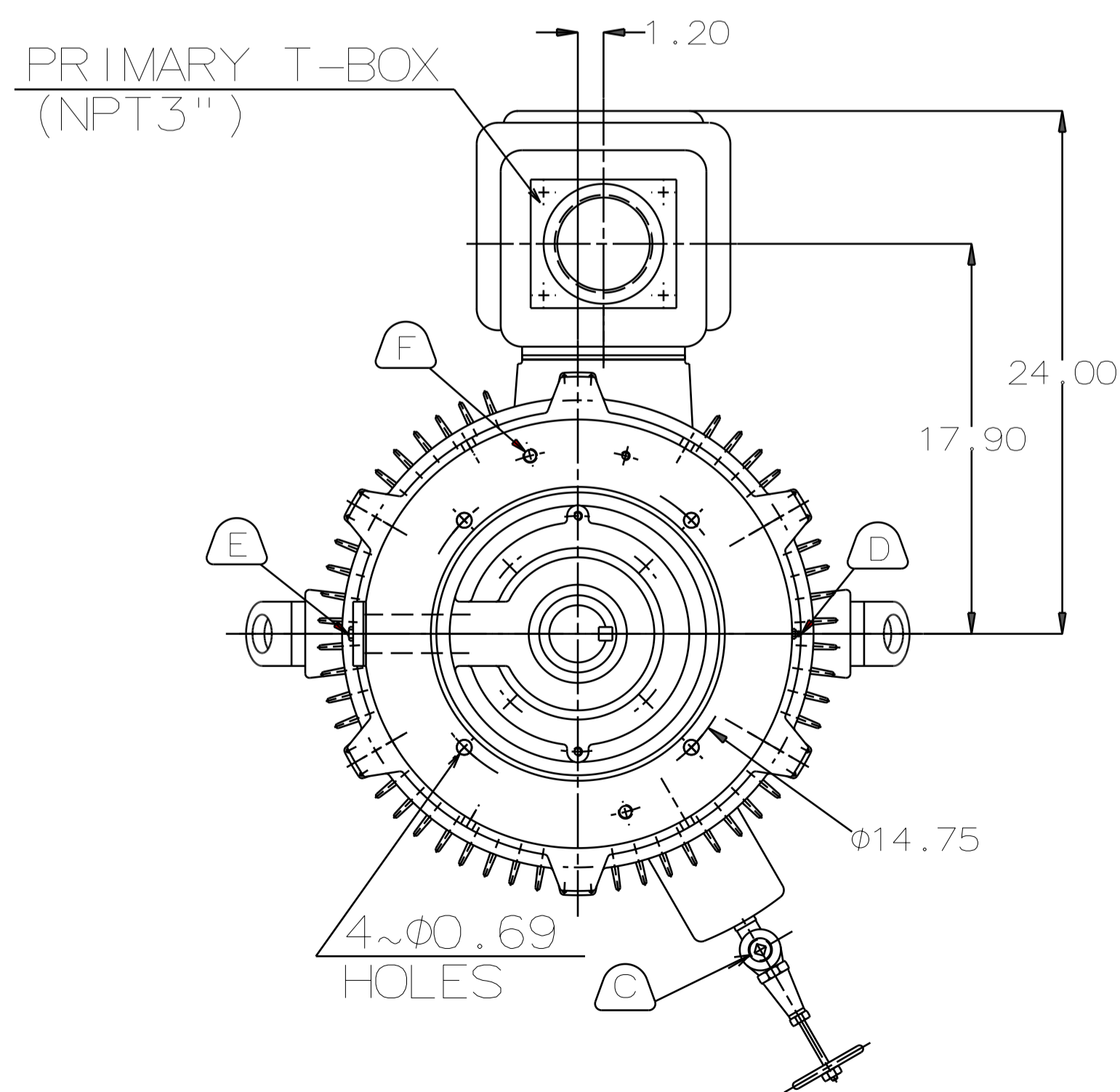

- A OIL FILLER [UPPER BEARING]
- B OIL GAUGE [UPPER BEARING]
- C OIL DRAIN [UPPER BEARING]
- D GREASE INLET [LOWER BEARING]
- E GREASE DISCHARGER [LOWER BEARING]
- F 2~M16 VERTICAL JACKING HOLES 180° APART IN MOTOR BASE.
- G M10 TAPPED HOLE IN MOTOR BASE WITH GROUNDING TERMINAL [R38-10] & BOLT LOCATED AS SHOWN.

DATE DEC 08 2016

OUTLINE DIMENSIONS

VSTP2506

3-PHASE INDUCTION MOTOR

DWN.	C.FU	APR.29.2015
CHKD.	R.LEE	APR.29.2015
APPD.	C.LIU	APR.29.2015

TECO Westinghouse

DWG NO. REV:01

4B040L257

6

5

4

3

2

1